

### 7.1.2 Inverter Based Generation One-Line Diagrams

The one-line diagrams presented in this section are illustrative of several typical inverter-based DG installations. The NEC may permit other configurations and may have additional wiring and equipment requirements. For the meters, S means Source and L means Load.

Generation Production meter wiring: Evergy wiring should be on the top (source lugs) and the Customer's wiring should be on the bottom (load lugs).

Figure 7-1 below, illustrates the typical one-line diagram for a Customer's DER Facility that is connected at a circuit breaker in the electric service/load panel. The NEC 120% rule<sup>16</sup> applies when the DER PoC is made on the opposite end of the load bus from the primary power source.

**Figure 7-1: Load Side DER with PoC in a Load Panel**

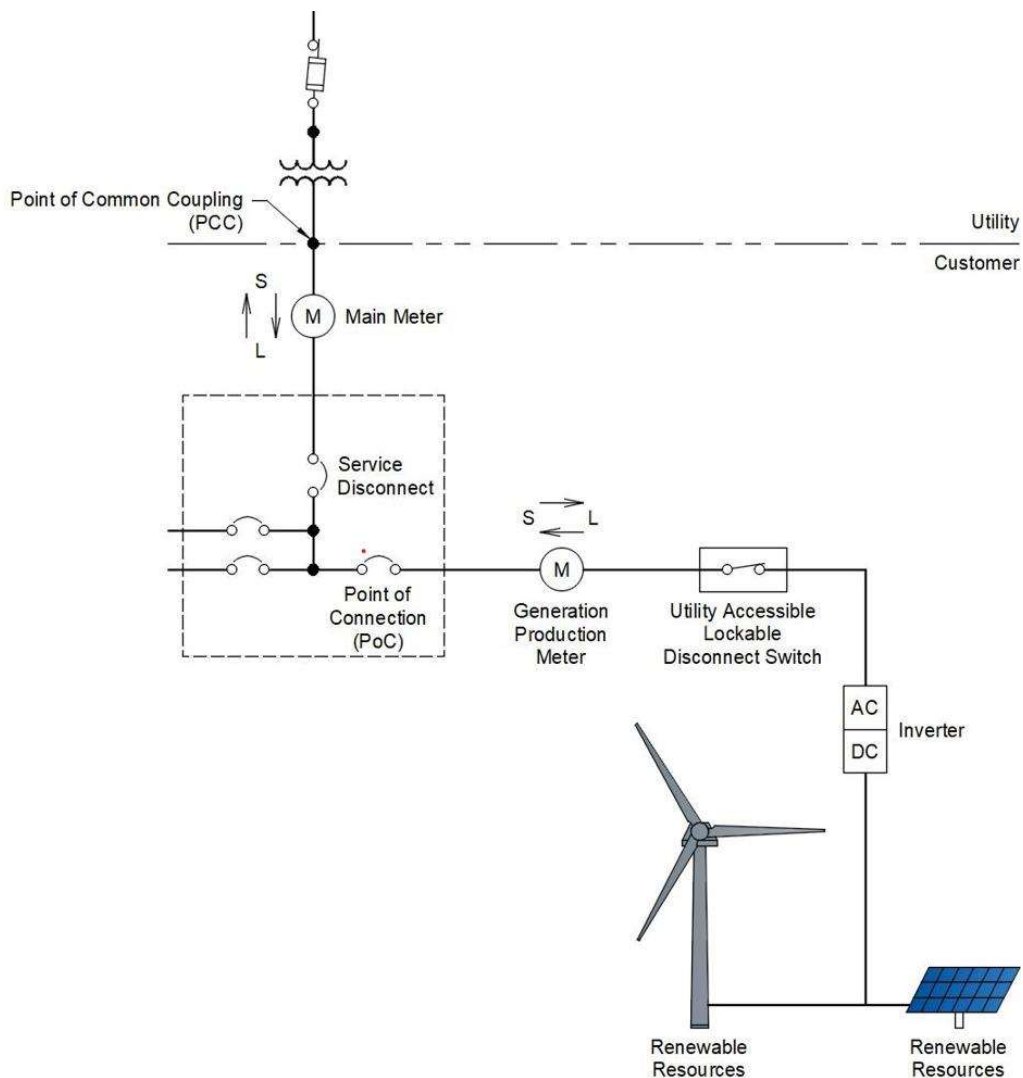

<sup>16</sup> NEC707.12(B)(3)(2)

Figure 7-2 below, illustrates the typical one-line diagram for a Customer's DER Facility that is connected on the load side of the Customer's service fuse/breaker disconnect, but ahead of a load panel. This configuration requires that the conductors and load panel, on the load side of the DER POC, be sized to carry the sum of the service and DER protective device ratings<sup>17</sup>.

**Figure 7-2: Load Side DER with PoC Ahead of a Load Panel**

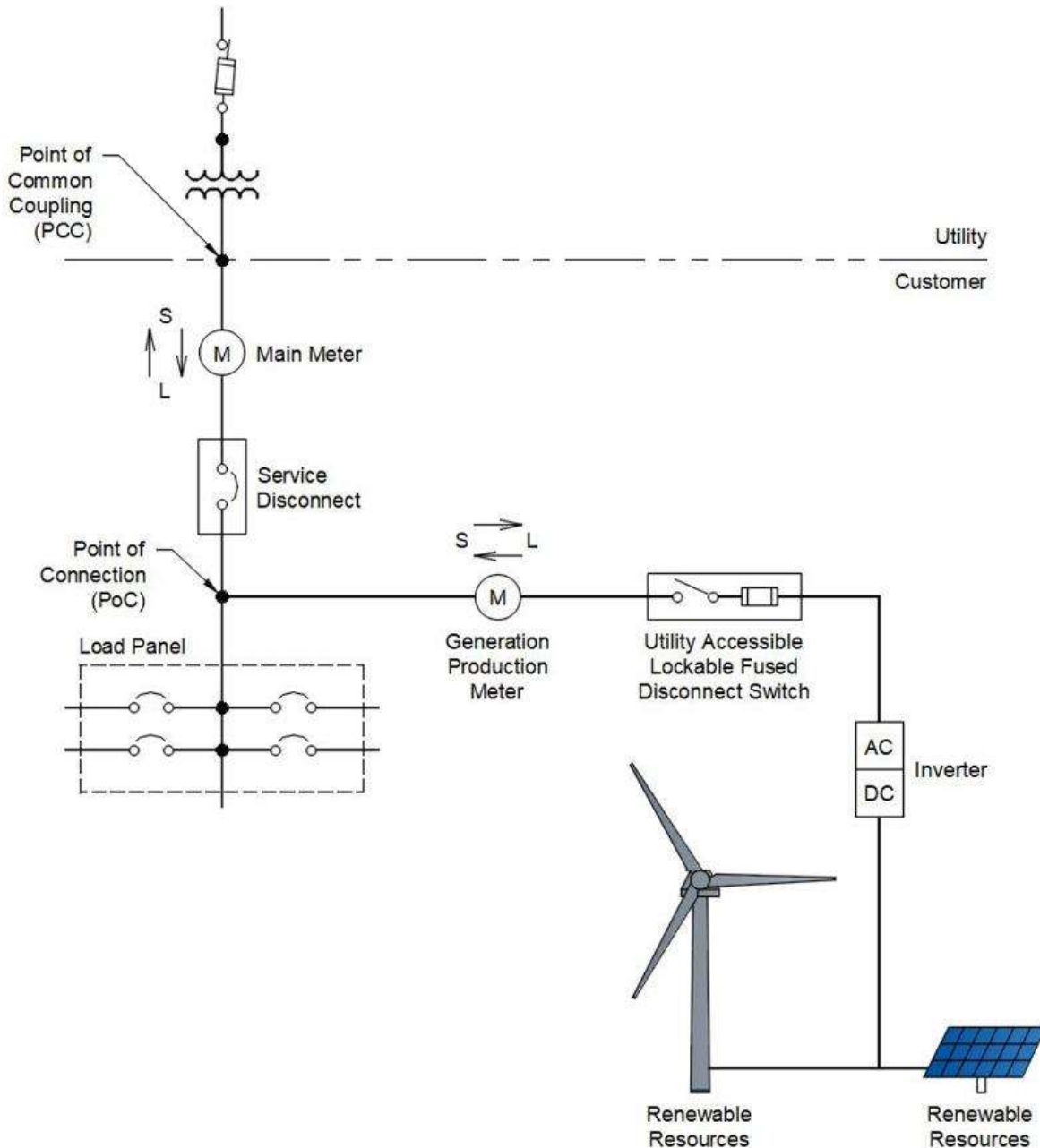

<sup>17</sup> NEC 705.12(B)(2) & (3)

Figure 7-3 below, illustrates the typical one-line diagram for a Customer's DER Facility that is connected after the Company service meter, but on the supply side of the Customer's service fuse/breaker disconnect using a double lugged meter enclosure. In this configuration, an existing meter enclosure may have to be changed to a meter enclosure that accommodates double lug load side connection.

**Figure 7-3: Supply Side DER with PoC at a Double Lugged Meter Enclosure**

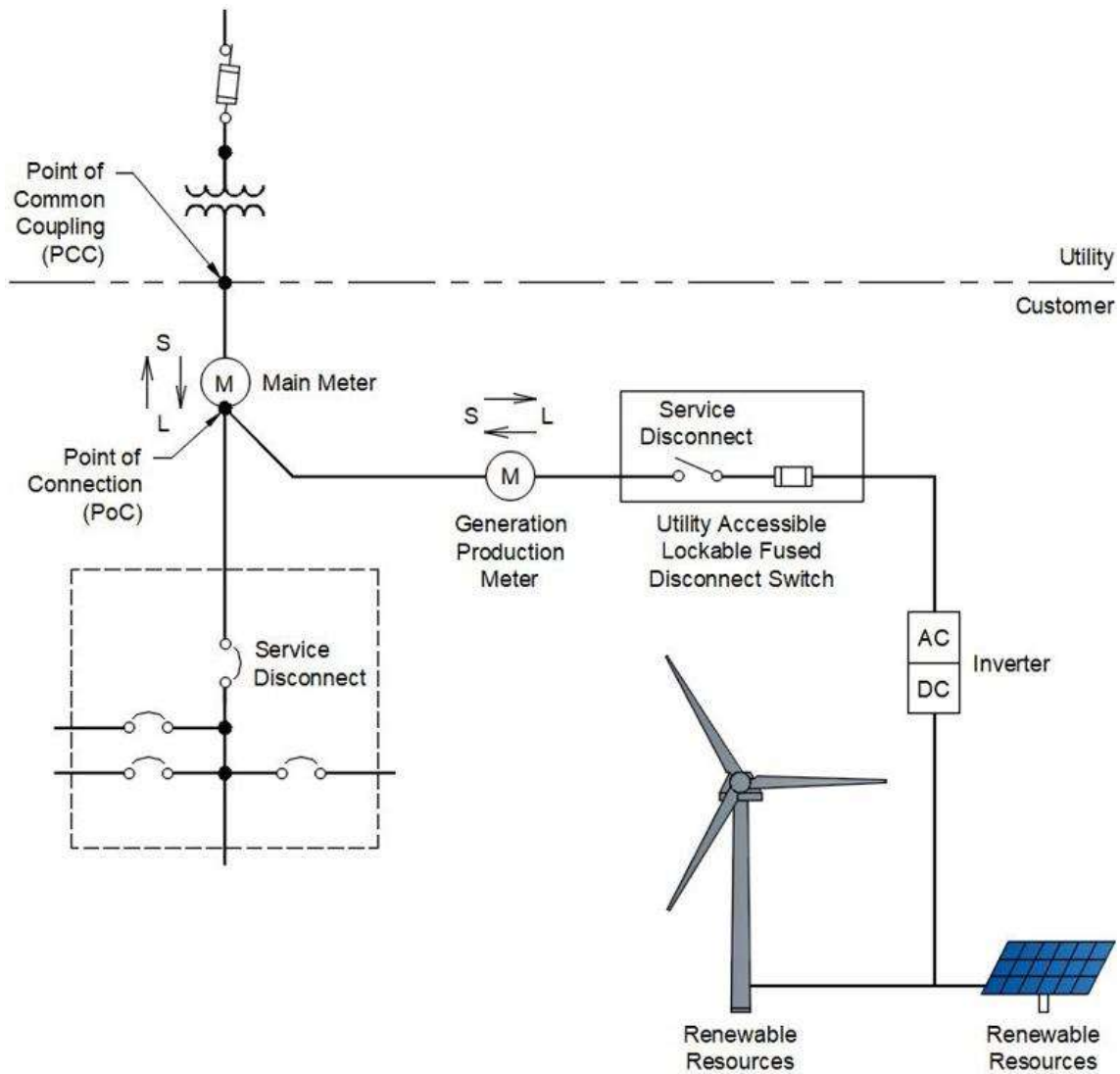
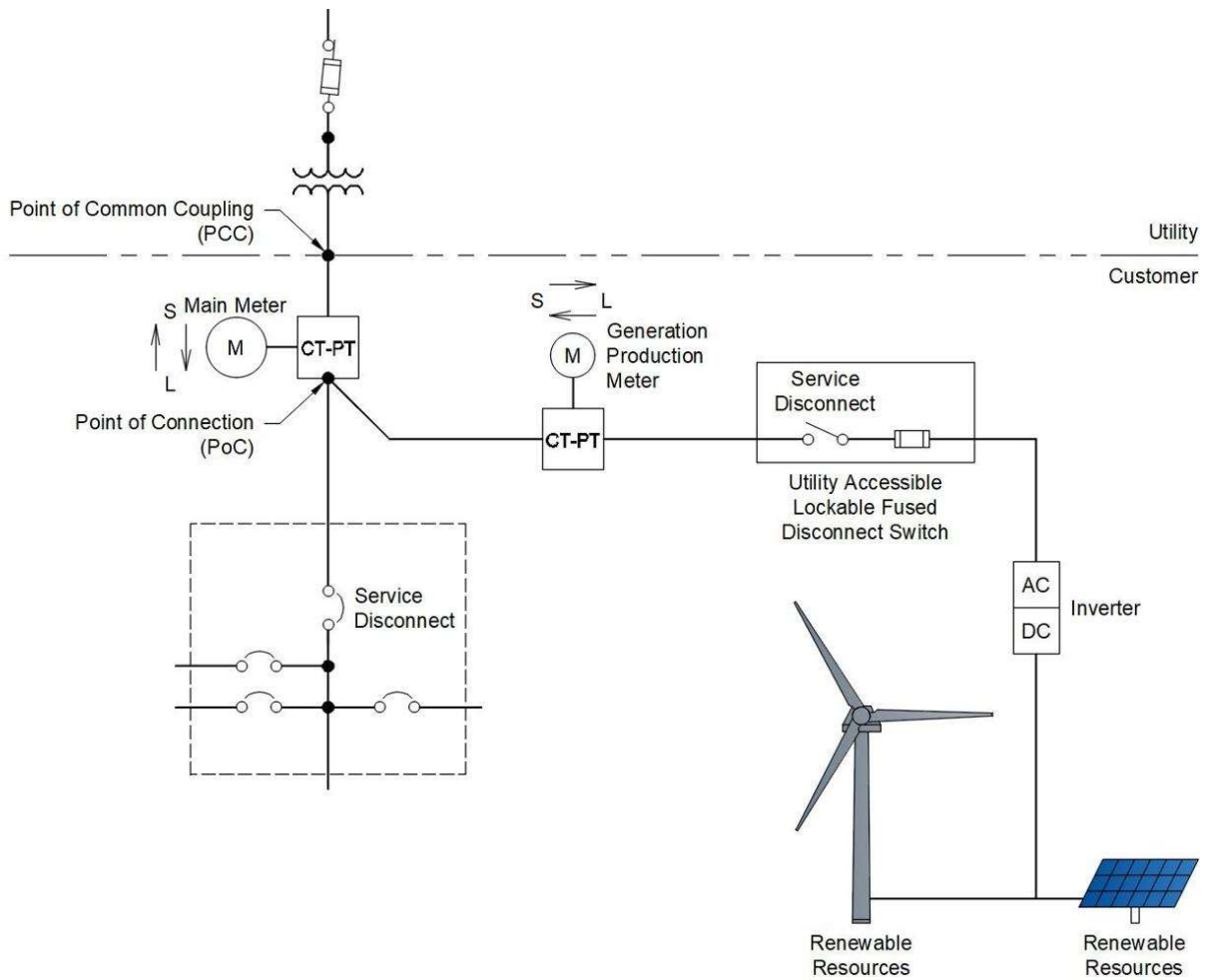

Figure 7-4 below, illustrates the typical one-line diagram for a larger Customer's DER Facility with an output rating greater than 200 amps which therefore requires CT generation metering. In this illustration the DER is connected in a junction box after the Company service meter, but on the supply side of the Customer's main service fuse/breaker disconnect. In this configuration the service meter enclosure must have the rating of the sum of the Customer's service disconnects, main and DER.

**Figure 7-4: Typical Inverter Based One-line Diagram with CT Metering**



## 7.2 Battery Energy Storage Systems (BESS)

Electric energy storage is considered a generator under the DER Facility definition in this Document. Battery energy storage systems are typically one part of a Customer Renewable Energy generation project and consist of batteries, Inverter(s), and an associated control system. BESS connections will be reviewed as part of the Customer’s DER Facility Interconnection Application and will be required to meet the technical and operational requirements of this manual.

Under Net Metering, a BESS can be paired with a Net Meter eligible Renewable Energy DER Unit. However, a BESS- only DER Facility is not eligible for the Net Metering program, as the energy stored may not be from renewable sources. A BESS-only DER Facility is eligible for Interconnection under the Parallel Generation-Non-Export or Parallel Generation-Qualifying Facility program. A BESS-only DER Facility may be allowed to export energy to the Company’s Distribution System when participating in a Company demand response or other grid services program and responding to a Company-issued dispatch instructions.

Customer BESS system with a critical load panel or TESLA Powerwall cannot participate in wholesale marketing.

### 7.2.1 BESS Standards

Company requires that Inverters of all BESS with Inverter-based interfaces be Certified to Underwriters Laboratories (UL) Standard UL 1741-SA and California Rule 21.

Company recommends that Customer propose Inverters listed as compliant on the California Energy Commissioner’s (CEC) list of eligible Inverters available at:

[www.energy.ca.gov/programs-and-topics/programs/solar-equipment-lists](http://www.energy.ca.gov/programs-and-topics/programs/solar-equipment-lists)

Company requires that the BESS be Certified compliant with the Battery and Energy Storage System Standards outlined in Table 7-2.

**Table 7-2: Battery and Energy Storage System Standards**

UL 1973	Batteries shall be Certified compliant with UL 1973 “Standard for Batteries for Use in Stationary, Vehicle Auxiliary Power and Light Electric Rail (LER) Applications”.
UL 9540	Energy Storage Systems shall be Certified compliant with UL 9540 “Standard for Energy Storage Systems and Equipment”.

Company recommends that Customer propose BESS components listed as compliant on the California Energy Commissioner’s (CEC) list of eligible Battery and Energy Storage Systems available at:

[www.energy.ca.gov/programs-and-topics/programs/solar-equipment-lists](http://www.energy.ca.gov/programs-and-topics/programs/solar-equipment-lists)

Customer may propose Inverter and BESS components that are not listed on the CEC list, but additional time will be required to verify certification and compliance with the specified requirements.

### 7.2.2 BESS One-Line Diagrams

The one-line diagrams presented in this section are illustrative of several typical DG plus BESS installations. The NEC may permit other configurations and may impose additional wiring and equipment requirements.

Figure 7-5 below, illustrates the typical one-line diagram for a Customer’s DER Facility with renewable DG and storage connected at a circuit breaker in the electric service/load panel. The NEC 120% rule<sup>18</sup> applies when the DER PoC is made on the opposite end of the load bus from the primary power source.

**Figure 7-5: Load Side DG plus Storage DER with PoC in a Load Panel**

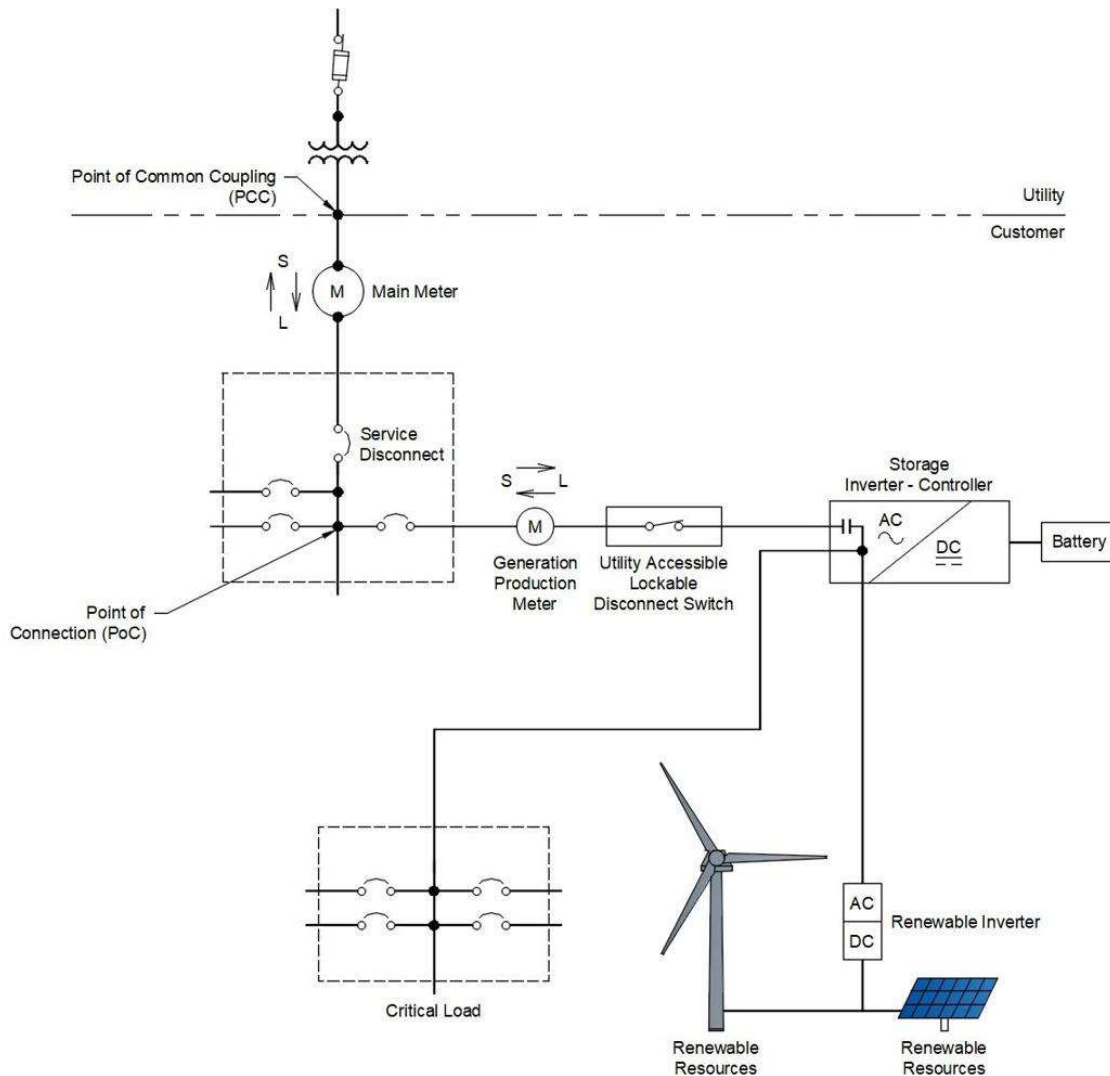

below, illustrates the typical one-line diagram for a Customer’s DER Facility with renewable DG and storage connected after the Company service meter, but on the supply side of the Customer’s service fuse/breaker disconnect using a double lugged meter enclosure. In this

<sup>18</sup> NEC707.12(B)(3)(2)

configuration the meter enclosure must have the rating of the sum of the Customers service disconnects, main and DER.

**Figure 7-6 : Supply Side DER with PoC at a Double Lugged Meter Enclosure**

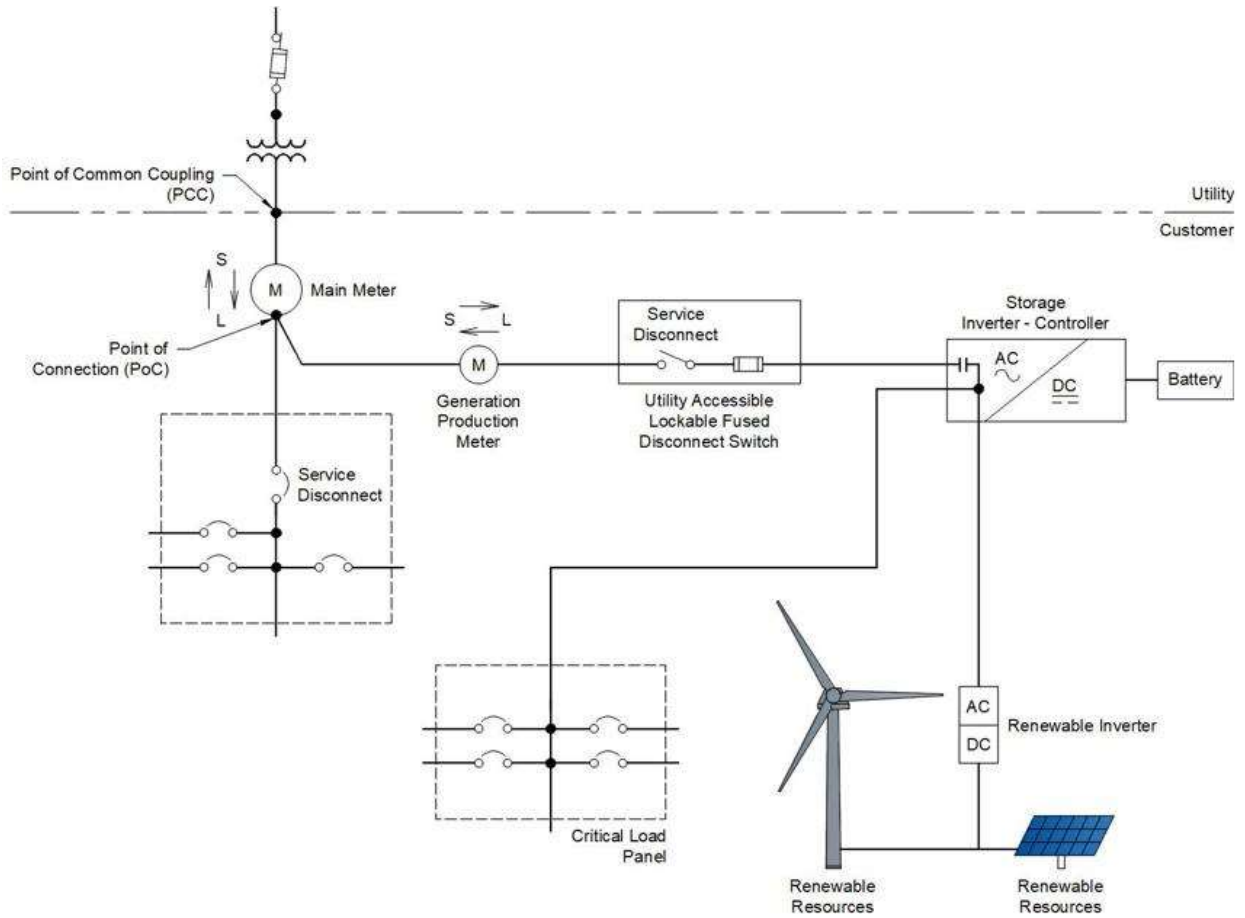



Figure 7-7 : Supply Side DER with PoC at a Double Lugged Meter Enclosure

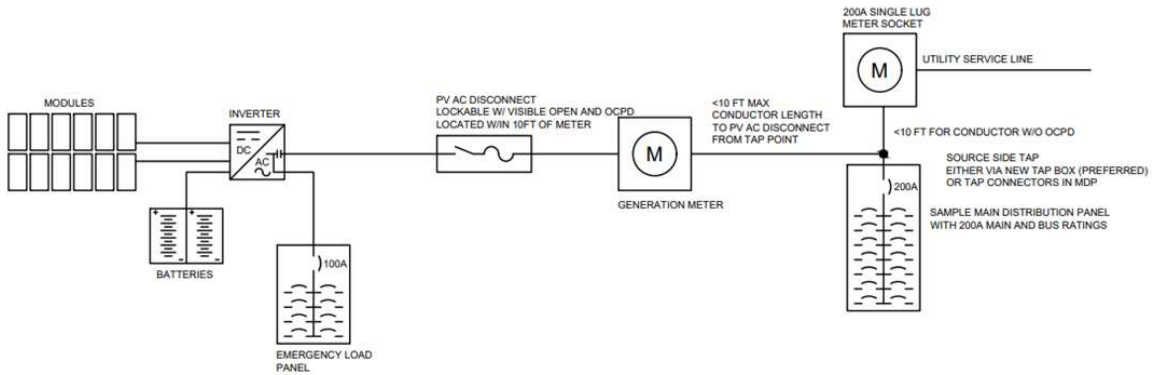

Figure 7-8 below illustrates the typical one-line diagram for a Customer’s DER Facility with renewable DG and storage connected after the Company service meter, but before the main distribution panel. In this configuration the AC disconnect will be ahead of the automatic transfer switch. The AC disconnect will only be operated by the utility during service work.

Figure 7-8 : Typical PV Install with TESLA Service Rated Gateway and Powerwall Battery

